

mesytec STM-16 is a shaping / timing filter amplifier with discriminator and multiplicity trigger. It is well suited for multistrip silicon detectors and for high quality spectroscopy applications. The differential input version is ideal with the preamplifier family MPR-16 / -32 / -64.

### Features STM-16:

- 16 channel NIM module, low power design
- Shaper amplifiers with baseline restorer
- Timing filter amplifiers
- Leading edge discriminators
- Digital delay of 450 ns for timing stop
- ECL timing output
- Trigger output
- Multiplicity trigger
- Option: Remote control of discriminator thresholds and gains

### New Features for STM-16+:

- 2 shaping times:  $0.4\mu\text{s}$  /  $1\mu\text{s}$  or  $2\mu\text{s}$  /  $5\mu\text{s}$   
(=  $1\mu\text{s}$  /  $2\mu\text{s}$  or  $5\mu\text{s}$  /  $12\mu\text{s}$  FWHM)
- Gain adjustable from 1 to 600
- Unipolar Lemo input option.
- Low noise:  $< 7\mu\text{V}$  (gain=100 and shaping time =  $2\mu\text{s}$ )
- Low integral nonlinearity

### Schematics:

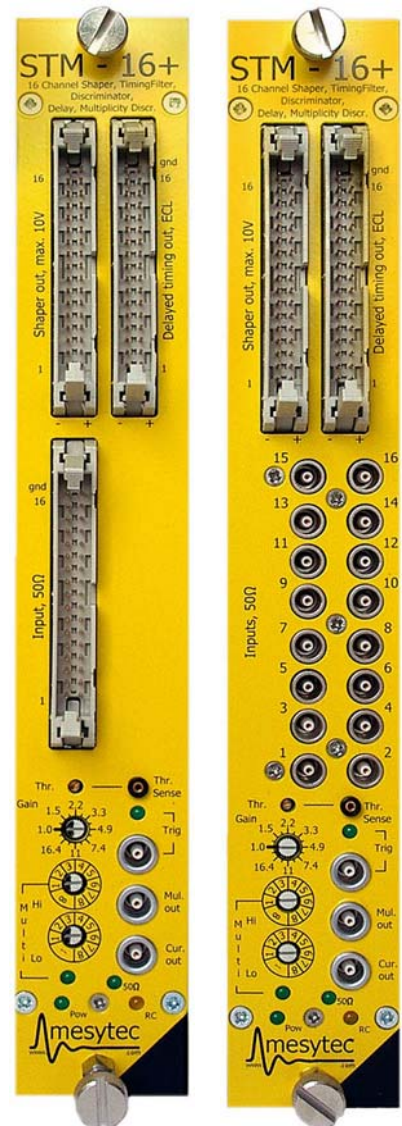
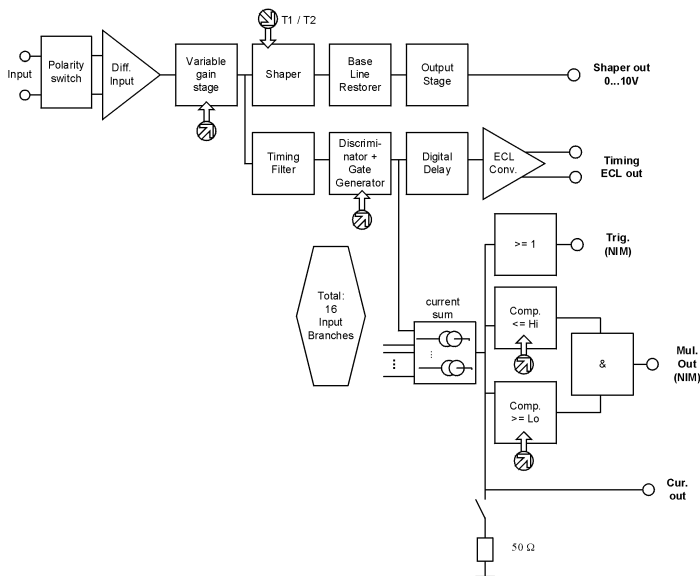

Differential Version      Unipolar Version

## Technical Data:

### Input stage

- Gain adjust: gain can be set from 1 to 20 in 16 steps with factor 1.22 per step.

#### differential version

- Input connector: 34 pin male connector
- Input resistance: terminated with 100  $\Omega$ , adapted to twisted pair cables.
- Gain-Polarity jumper with multiplication factor of 2 and 30 are standard. (Gain range from 2 to 600)
- input noise at gain = 100: 10  $\mu$ Vrms for 1  $\mu$ s shaping time, 7  $\mu$ Vrms for 2  $\mu$ s shaping time.
- Common mode suppression: 50 dB

#### unipolar version

- 16 Lemo 00 input connectors
- Input termination option: 1k and 50 Ohm, coded on the gain-polarity jumper.
- Gain-Polarity jumper with multiplication factor 2 and 30 are standard. Option: multiplication factor 1.
- input noise at gain = 100 and 2  $\mu$ s shaping time = 7  $\mu$ Vrms.

### Choose the Polarity:

The gain jumper (small plug on module near the front panel) can be plugged in in two positions, one nearer to the frontpanel (negative input polarity) and the other, one connector pitch nearer to the module middle (positive input polarity). Near one side of the module there is a store position for an unused Jumper module.

### Shaper:

- PZ adjustable with trimmers inside the case from 8  $\mu$ s to infinity.
- Two shaping times of 0.4  $\mu$ s / 1  $\mu$ s or 2  $\mu$ s / 5  $\mu$ s jumper selectable, common for all channels.
- Output amplitude: 0 to 10 V
- Passive baseline restorer
- DC-Offset: VDC  $\pm$  5 mV, common offset adjust.
- Output connector: 34 pin male connector
- Integral nonlinearity < 0.05%
- gain drift < 0.0075% /  $^{\circ}$ C
- Offset drift < 50  $\mu$ V/  $^{\circ}$ C

### Timing filter amplifier:

- RC-CR, 7 ns / 100 ns
- 4 monitor outputs for timing filter signals, each providing the sum signal of 4 channels (Amplitude: -1.5 V per channel for 10 V shaper output)

### Discriminator:

- Leading edge
- Threshold: adjustable, 0 to 4 V (= 0% to 40% of maximum range)

### Gate generator, Timing delay, ECL output

- Pulse width for trigger output: 400 ns
- Timing stop- ECL-Signals: delay 400 ns from trigger, width 200 ns
- Output connector: 34 pin male connector
- Typical timing resolution for 5 MeV signals from silicon detector (10 \* 10 mm<sup>2</sup>, 500  $\mu$ m, 60V bias): dT = 400 ps. If necessary, a walk correction can be easily implemented in software using the shaper amplitude.

### Multiplicity trigger:

- Each channel above threshold contributes to multiplicity level, a multiplicity trigger is generated for: lower multiplicity threshold  $\leq$  multiplicity level  $\leq$  upper multiplicity threshold
- coincidence interval adjustable from 40 ns up to 150 ns (default 100 ns).
- The multiplicity trigger is 100 ns delayed to the trigger signal.
- Lower multiplicity threshold: 1 ... 8, upper multiplicity threshold: 1 ... 8 and  $\infty$
- Multiplicity chaining: multiplicity outputs from several modules can be connected, resulting in a total multiplicity level of all connected modules. Multiplicity trigger windows of the connected modules act independently on the total multiplicity.

### Power consumption: (max 7W)

- +6V 280 mA
- -6V -680 mA
- +12V 80 mA

## Remote Control

The STM-16 can be equipped with a remote control option which is separately available .

The NIM-controller module MRC-1 is necessary as a bus master. One MRC-1 can control 32 various mesytec modules. Communication with a control PC is done via RS-232 serial interface.

The **discriminator thresholds** can be individually adjusted from

*0..40% of the maximum range in 256 steps.*

The **gain** can be adjusted for pairs of channels in 16 steps:

*setting 0 = gain 1,*

.

.

*setting 15 = gain20,*

The parameters are organised in a 32 word memory array. The gain parameters are situated at the even position 0,4,8...30 (channel 1/2 .. channel 15/16) , the thresholds are situated at the odd positions 1...31 (channel 1..16)

The commands are transmitted via event bus, which can be connected to the rear side of the STM-16 module. The ID-number which is set with the coder identifies the module in the bus chain and must be unique for one bus line.

### Rear side of STM-16:



Coder for 16 bus addresses (0..F)

Bidirectional event bus

Power supply output for preamp MPR-16

Timing filter sum outputs in groups of 4 channels (1-4, 5-8, 9-12, 13-16)

### View on the PCB with servicable trimmers

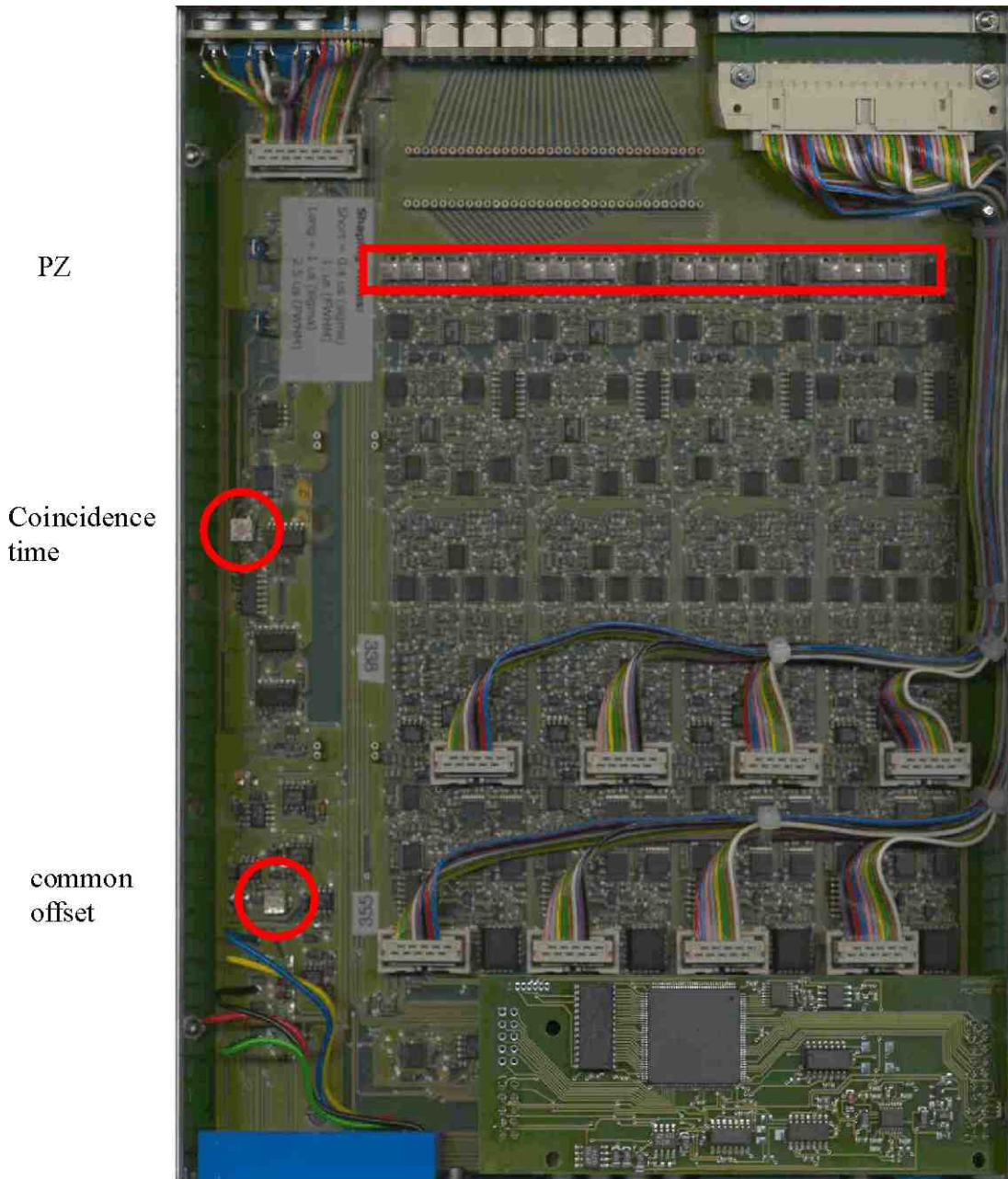

## Memory List STM-16+:

ADR	GAIN/THR	ADR	GAIN/THR
0	gain 1 and 2	16	gain 9 and 10
1	threshold 1	17	threshold 9
3	threshold 2	19	threshold 10
4	gain 3 and 4	20	gain 11 and 12
5	threshold 3	21	threshold 11
7	threshold 4	23	threshold 12
8	gain 5 and 6	24	gain 13 and 14
9	threshold 5	25	threshold 13
11	threshold 6	27	threshold 14
12	gain 7 and 8	28	gain 15 and 16
13	threshold 7	29	threshold 15
15	threshold 8	31	threshold 16

The memory positions can be written with SE command and can be read with RE command. A mirror page is available. It can be written with SM and read with RM and copied with CP.

The commands RST sets all thresholds to the value 32 and all gains to the value gain = 2.

The ON/OFF command makes the remote control active or inactive. The power up default is inactive. While inactive the manual values from the front panel elements are set.

Identification code for STM (detected when running the scan bus command "SC") is IDC = 19

### Example:

reset all channels of STM-16 module ID 7 on bus 0 to defined values:  
RST 0 7

to set the channel 3 and 4 of module with ID 7 on bus 0 to gain = 1.5 and the threshold of channel 3 20% type:  
SE 0 7 4 2 //set gain of channel 3 and 4 = address 4  
SE 0 7 5 128 // set threshold of channel 3 = address 5

activate remote control  
ON 0 7

## Command Summary:

data formats:

*bus* = bus number [0...1]

*dev* = device number [0...15]

*adr* = parameter number [0...31]

*gain* = [0...15]; gain from 1 to 20 in steps of factor 1.22;

*thr* = [0...255]; 0..255 corresponds to threshold 0..40% maxrange

## Mnemonic

## Description

SC <i>bus</i>	STM 16 allows scan bus, returns id code: IDC=19
ON bus dev	activate RC
OFF bus dev	deactivate RC
SE <i>bus dev adr gain/thr</i>	set gain(even address) or threshold (odd address)
RE <i>bus dev adr</i>	read gain or threshold value
RST <i>bus dev</i>	reset gain and threshold to default values
SM <i>bus dev adr gain/thr</i>	set mirror parameter (even address = gain, odd address = threshold)
RM <i>bus dev adr</i>	read mirror cell
CP	copy mirror to active memory